

The Experimental Study of Nanoparticles Effect on Thermal Efficiency of Double Pipe Heat Exchangers in Turbulent Flow

R. Aghayari^{1,*}, H. Maddah², F. Ashori¹, M. Aghili¹

¹ shahrood Branch, Islamic Azad University, Shahrood, I.R. Iran

² Chemical Engineering Department, Arak Branch Islamic Azad University, Arak, I.R. Iran

ARTICLE INFO:

Article history:

Received 27 November 2013

Accepted 25 June 2014

Keywords:

Nano particles

Double-pipe

Heat Exchanger

Turbulent Flow

Heat Transfer Coefficient

Abstract

In this work, the characteristics of flow and heat transfer of a fluid containing nano particles of aluminum oxide with the water volume fraction (0.1-0.2-0.3)(V/V) percent of the reports. The overall heat transfer coefficient, heat transfer and the average heat transfer fluid containing nano water - aluminum oxide in a horizontal double pipe counter flow heat exchanger under turbulent flow conditions is studied. In the present study, aluminum oxide nanoparticles with a diameter of about 20 nm are used. The results show that the overall heat transfer coefficient and the overall heat transfer fluid based on nano-fluid heat transfer coefficient is slightly higher (up to about 5-12 percent). Nano-fluid heat transfer coefficient and average heat transfer increased with nano-fluid mass flow rate increases with increasing temperature and water nano-fluid, fluid temperature increases and Heated (Author) nano-fluid heat transfer coefficient is greatly influenced. The use of nano-fluid pressure may cause slight errors in the calculation.

1. Introduction

Application of nano-technology in classical thermal designs lead to Nano-Fluid (NF) as a new class of heat transfer fluids. Since conventional Heat Transfer (HT) fluids including water, oil, Ethylene Glycol (EG) show relatively poor HT characteristics, NF has been introduced. By dispersing solid particles, fibers or tubes of 1 to 50 nm length in conventional HT fluids, NFs are formed. There are remarkable characteristics associated with NFs such as: high HT rate, low fluculation ability through passages, thermal

homogeneity. In this view, NFs found extensive demand in electronics and automotive industries to name but a few. Consequently, further study of HT of NF suspensions seemed necessary. The advances in nanotechnology have resulted in the development of a category of fluids termed nanofluids, first used by a group at the Argonne National Laboratory in 1995 [1]. Nanofluids are suspensions containing particles that are significantly smaller than 100 nm [2], and have a bulk solids thermal conductivity of orders of magnitudes higher than the base liquids.

Experimental studies conducted have shown [3,4,5] that the effective thermal conductivity increases under macroscopically stationary conditions. Lee and Choi under laminar flow conditions, nanofluids in micro-

*Corresponding author

Email address: Reza.aghayari63@yahoo.com

Nomenclature		Greek Symbols	
A	heat transfer area (m ²)	ΔT_{lm}	logarithmic mean temperature difference(°C)
C_p	specific heat (kJ kg ⁻¹ °C ⁻¹)	α	thermal diffusivity (m ² /s)
D	tube diameter (m)	ρ	density (kg m ⁻³)
d	nanoparticle diameter (m)	ϑ	Kinematic viscosity (m ² /s)
h	convective heat transfer coefficient (W m ⁻² °C ⁻¹)	ϕ_v	nanoparticle volume concentration (Dimensionless)
k	thermal conductivity (W m ⁻¹ °C ⁻¹)	Subscripts	
L	tube length (m)	f	fluid
\dot{m}	mass flow rate (kg s ⁻¹)	i	inside
Nu	Nusselt number (Dimensionless)	in	inlet
Pe	Peclet number (Dimensionless)	m	mean
Pr	Prandtl number (Dimensionless)	nf	nanofluid
Q	Heat transfer rate (W)	o	outside
Re	Reynolds number (Dimensionless)	out	outlet
T	Temperature (°C)	p	particles
U	overall heat transfer coefficient (W m ⁻² °C ⁻¹)	w	wall
V	Velocity (m.s-1)		

channels have shown a two flow reduction in thermal resistance [6] and dissipate heat power three times more than that of pure water. Studies conducted using water-Cu nanofluids [7] of concentrations approximately 2% by volume was shown to have a heat transfer coefficient 60% higher than when pure water was used. Such advances must have a broader impact culminating in promoting teaching, training and learning. Dissemination of research results will enhance the scientific and technological understanding of nanotechnology. This effort aims at bringing nanotechnology to the undergraduate level, especially at the applied level in engineering and technology curricula. The focus is to incorporate nanotechnology into existing course curricula such as heat transfer and fluid mechanics. The intention of the work described here is to introduce a simple experimental procedure in a heat transfer course to facilitate the understanding of the convective heat transfer behavior of nanofluids.

He et al [8] reported an experimentally study that investigated the heat transfer performance and flow characteristic of TiO₂-distilled water nanofluids flowing through a vertical pipe in an upward direction under a constant heat flux boundary condition in both a laminar and a turbulent flow regime. Their results showed that at a given Reynolds number and particle size, the heat transfer coefficient raised with increasing nanoparticle concentration in both laminar

and turbulent flow regimes. Similarly, heat transfer coefficient was not sensitive to nanoparticle size at a given Reynolds number and particle size. Moreover, the results indicated that the pressure drop of the nanofluids was very close to that of the base fluid.

2. Experimental

2.1. Experimental setup

The apparatus employed in this work is schemed in figure1 the device comprises: a test chamber, two storage tanks, two magnetic gear pumps; one to circulate Nano-Fluid (NF) known as 'hot fluid' while the other to pump cooling fluid in a loop. The test chamber is a double tube counter current heat exchanger 120 cm long. The Nano-Fluid (NF) flows inside the tube while cooling fluid (water) flows through the outer tube. The inner tube made from soft copper 6 mm ID. and 8 mm OD. The outer tube made from steel 14 mm ID. and 16 mm OD. Plastic insulator is used for the upper and lower sections of the test chamber to reduce the heat loss. The test chamber equipped with four thermometers located at the input and output streams of both hot NF and cooling fluid. The two storage tanks each 15 and 20 liters volume made from stainless-steel and plastic to store hot NF and cooling water.

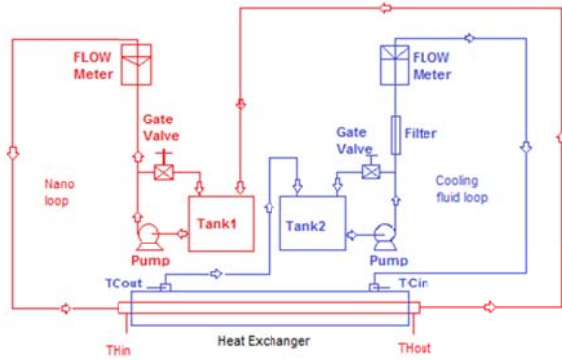

(a)



(b)



(c)

Fig.1. Experimental setup.

The NF storage tank equipped with an electric heater and a thermostat to maintain the temperature of hot NF.

Accordingly, the water storage tank is equipped with a cooling device and a thermostat to maintain the temperature of cooling water.

Nanofluid preparation

The nanofluid used in the experiment was 99.0+% pure aluminium oxide pre-dispersed in water, with an average particle size of 20nm. The XRD spectra and the SEM image and TEM Image of the prepared

sample are shown in Figures 2, 3 and 4, respectively. The nanofluid was mixed with de-ionized water to prepare experimental concentrations. It has been reported by researcher that nanofluids with less than 4% nanoparticles were found to be stable and the stability lasted over a week, no intermediate mixing was considered necessary.

3. Result and Discussion

The hot water from the heat and cool the liquid absorbs heat through the following relationship. In these relationships from the data recorded temperature and mass flow used in fact this amount of heat absorption and heat lost must be equal with the accuracy of the method, of course. The measurement also depends on measuring method of error in our research is less than 10%.

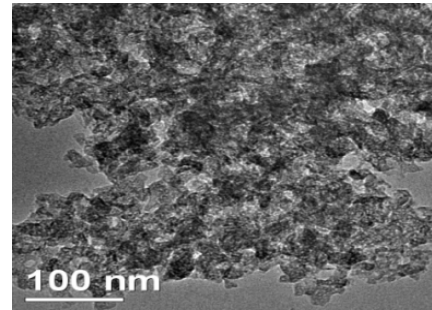

Fig. 2. XRD pattern of Al₂O₃ particles

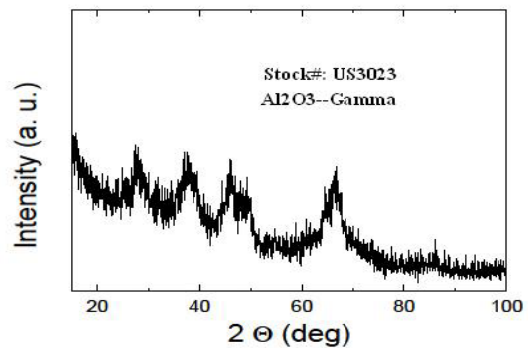

Fig. 3. SEM photograph of Al₂O₃ particles.

The heat transfer rate into the Nano fluid (hot fluid) is computed from:

$$Q_{(nano\ fluid(hot\ fluid))} = \dot{m}_{(nano\ fluid(hot\ fluid))} C_{p(nano\ fluid(hot\ fluid))} (T_{out} - T_{in}) \tag{1}$$

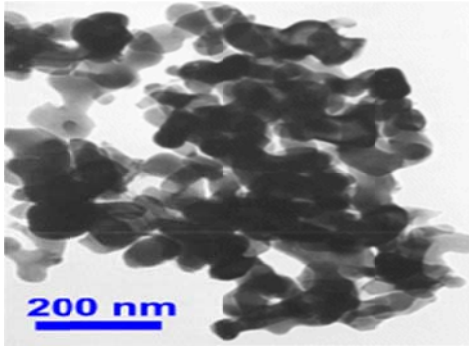

Fig. 4. TEM photograph of Al₂O₃ particles.

Where \dot{m} is the mass flow rate of the nanofluid(hot fluid), and T_{out} and T_{in} are the outlet and inlet temperatures of the nanofluid(hot fluid), respectively.

while the heat transfer of the cold fluid (water) for the outer tube is:

$$Q_{(cold\ fluid(water))} = \dot{m}_{(cold\ fluid(water))} C_{p(cold\ fluid(water))} (T_{in} - T_{out}) \quad (2)$$

Where \dot{m} is the mass flow rate of the water (cold fluid), and T_{in} and T_{out} are the inlet and outlet temperatures of the water (cold fluid), respectively.

Where is the heat transfer rate of the cold water and is the mass flow rate of the cold water. The average heat transfer rate is defined as follows:

$$Q_{(average)} = \frac{(Q_{nano\ fluid} + Q_{cold\ fluid})}{2} \quad (3)$$

Where is the average heat transfer rate between the hot water and the nanofluid.

$$T_{(hot)average} = \frac{T_{(hot(out))} + T_{(hot(in))}}{2} \quad (4)$$

$$T_{(cold)average} = \frac{T_{(cold(in))} + T_{(cold(out))}}{2} \quad (5)$$

To calculate heat capacity can be a famous relationship nanofluid Choi and Associates help:

$$(C_p)_{nano\ fluid} = (1 - \phi_v)(C_p)_{basis\ flow} + \phi_v(\rho C)_{particle} \quad (6)$$

$$Q_{(average)} = U A \Delta T_{(log\ main\ temperature\ difference)} \quad (7)$$

$$U = \frac{Q_{(average)}}{A_{(average)} \Delta T_{(log\ main\ temperature\ difference)}} \quad (8)$$

$$\Delta T_{(log\ main\ temperature\ difference)} = \frac{(T_{hot(out)} - T_{cold(in)}) - (T_{hot(in)} - T_{cold(out)})}{\ln \left[\frac{(T_{hot(out)} - T_{cold(in)})}{(T_{hot(in)} - T_{cold(out)})} \right]} \quad (9)$$

Is observed when nano liquid aluminum oxide as the hot fluid is considered to be a flow rate of heat compared to water increased obviously in the form of (1,2) can be seen as the Reynolds number of approximately 15,600 of the heat transfer average hot water at about 673 and 675 watts for the nano-fluid with 0.1 at about 713 and 717 watts is. However this temperature is 35 ° C and at the same Reynolds, but at 40 ° C the value for water is about 915 and 961 nm and for liquids with a viscosity of about 950 and 1030 is 0.1, which shows the effect of increasing the temperature of the nano-fluid.

Figures 7a-7b overall heat transfer coefficient of water, aluminum oxide nano-fluid volume than the Reynolds number density of particles in the show. The result comes on the overall coefficient of heat transfer of nano-fluid in turbulent flow with increasing Reynolds number and the temperature rises, for example, we can see that the Reynolds 23000 The amount of water in 2120 and 2440 at 35 ° C for nano-fluid concentrations of 0.2 at 40 ° C by about 2301 and 2556 are. The properties of the aluminum oxide-water nano-fluid were examined results confirm The nano-fluid heat transfer efficiency is generally higher bulk density than water particles increases the overall heat transfer coefficient is higher rates when the crime rate higher increase in temperature we have tangible impact on Transfer Rate coefficient of general Heat would be the result in addition to the accumulation of nano particles and fluid temperature is their performance on Structure also in the performance of heat transfer fluid nanotechnology will be effective. Finally, the surface properties affect the heat exchanger and are an important factor that must be considered.

Based on the experimental results, introducing nano-particles to the fluid, will increase heat transfer coefficient of the system in turbulent regimes. Surface properties, particle shape and concentration of nano-particles play important role to improve NF heat transfer properties. The elevated heat transfer

coefficient may attribute to the higher concentrations of nano-particles adjacent to the wall caused by particle migration phenomenon. The momentum of suspended particles increases as the NF mass flow rate increases. Accordingly, the collision of nano-particles to the wall become even more intense. Friction to the wall as a function of wall surface properties and NF characteristics may need to study. Further research is required to better understanding the NF heat transfer properties and develop more relations.

4. Conclusions

Experimental results showed that the addition of nano-particles in the fluid, the average heat transfer coefficient of the system increases the turbulent flow regime. Particle shape, density and surface properties of nanoparticles are key factors to improve the heat transfer characteristics of nano-fluids. This increases the heat transfer coefficient may be due to the high density of nano particles on the pipe wall is due to immigration. The heat transfer characteristics of nano-fluids for greater recognition and extensive research is needed to obtain other relations. The intensity of the collision of particles in nano fluid with an increase in the fluid mass flow is more that this would strongly deal with the exchanger walls also increases the friction as well as according to the type of nano-fluid and the properties of the walls of the heat exchanger can be determined.

In general add nano particles by using three mechanisms will increase heat transfer:

A) Nano particles have higher heat guide and the higher density of particles more increase in transfer of heat as a result.

b) Nano particles with fluid molecule based on the wall and turned into heat and the cause of increase in energy.

c) Nano fluid friction between fluid and the wall tube increased and will improve heat exchange.

The intensity of the collision of particles in nano fluid with an increase in the fluid mass flow is more that this would strongly deal with the exchanger walls also increases the friction as well as according to the type of nano-fluid and the properties of the walls of the heat exchanger can be determined.

One reason for this difference in heat transfer at high Reynolds numbers, the high viscosity of nano-rod fluid. In general, the fluid containing rod-shaped particles, due to severe reactions have high viscosity and high density in shear flow. So this is also one of the factors reducing heat transfer to the rod-shaped nanoparticles are spherical mode.

In this experiment, the spherical shape of the nanoparticles have been studied. Particle concentration and movement of particles in the flow of other factors that affect the heat transfer. Nano-Fluid is assumed that the main mechanism for increasing the thermal conductivity of nanoparticles is a transitional move. The mobility of smaller particles than for larger particles predicted and therefore increase the coefficient of thermal conductivity of nanofluids by the finer particles than coarse particles.

Nanofluids flow by regulating the rotation speed of the magnetic gear pump are three modes that control. Temperature measurement using thermocouple data logger and a very low error rate, even as much interest in evaluating the heat transfer has been calculated. The mass flow rate was measured with an electronic scale and recorded. Electronic scale error ± 0.0006 kg. The maximum error of 2.2% mass flow of nanofluids were measured. Heat transfer for the error calculation also consider the error. As noted above, it is evident that the error in the measured heat transfer is determined by measuring the temperature and the amount of cold water and nanofluids depends. The measured heat transfer were calculated using the square root of the sum of mean and 10%, respectively. During the test, a test of the mass flow rate and cooling water outlet temperature and inlet water nanofluids, nano-fluids measured cold.

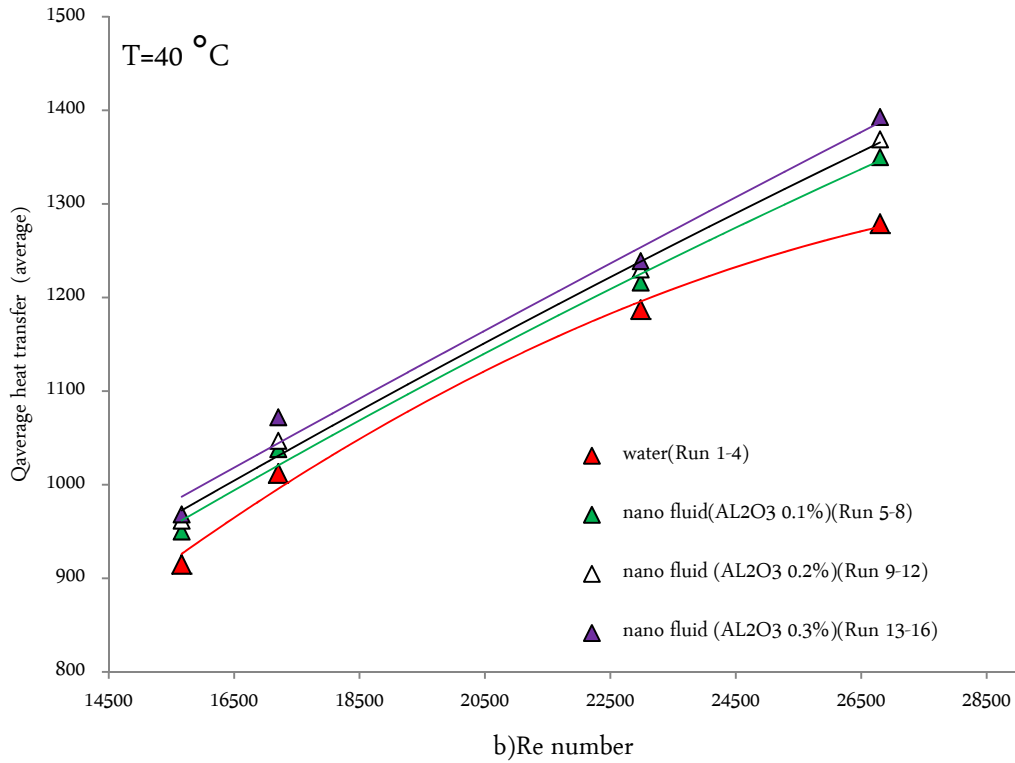
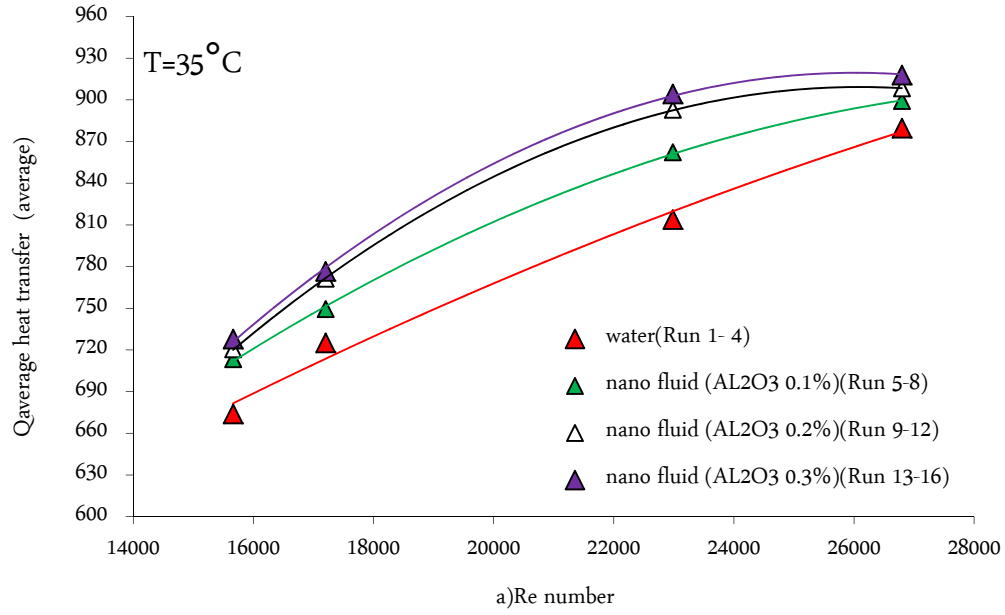

Fig.5. Average heat flow rate of the Reynolds number at a) 35 and b) 40 °C.

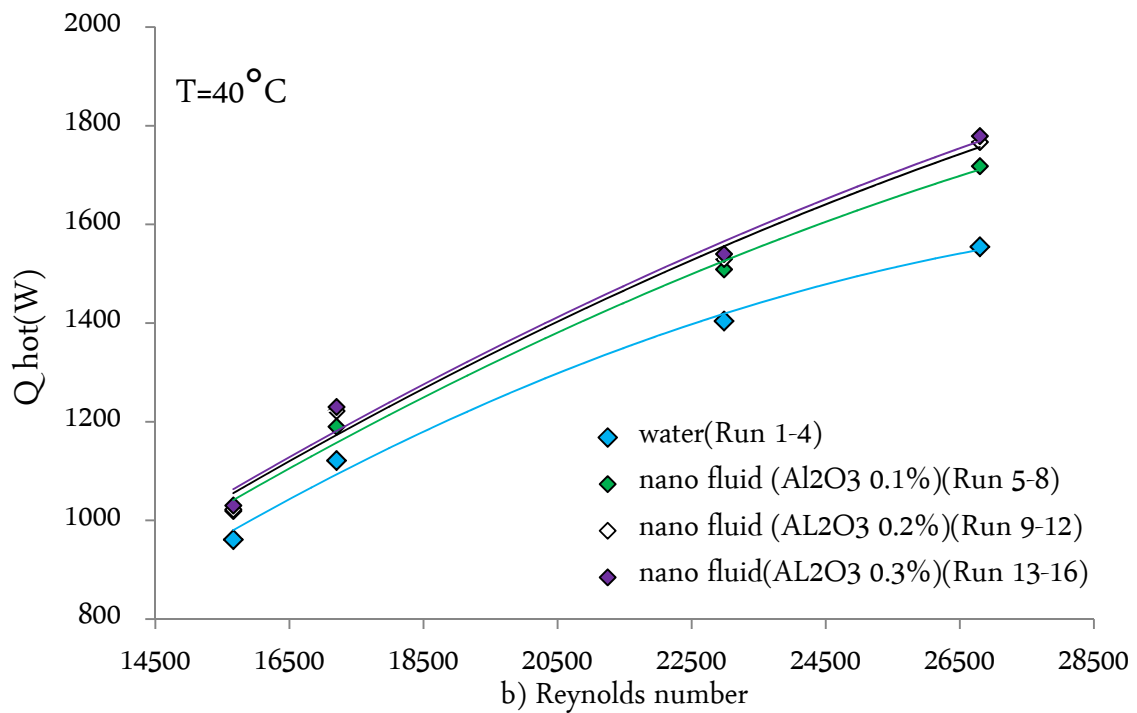
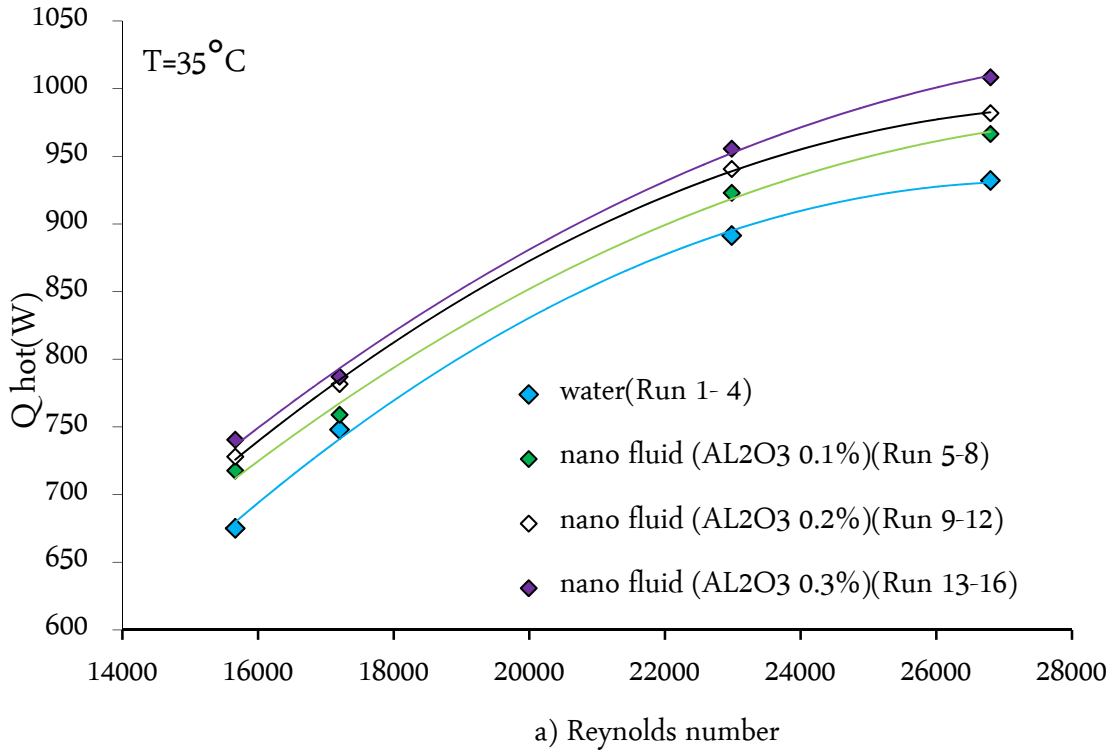

Fig.6. the rate of heat flows Reynolds numbers at a) 35 and b) 40 °C.

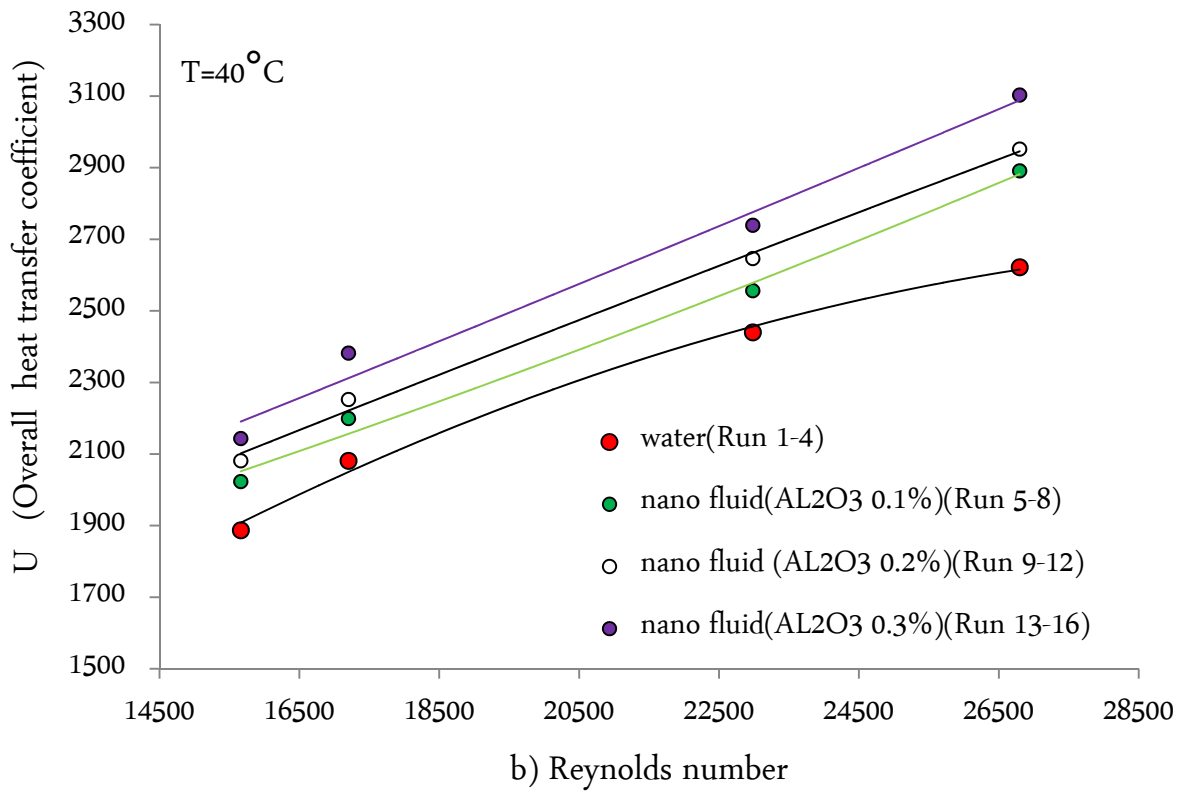
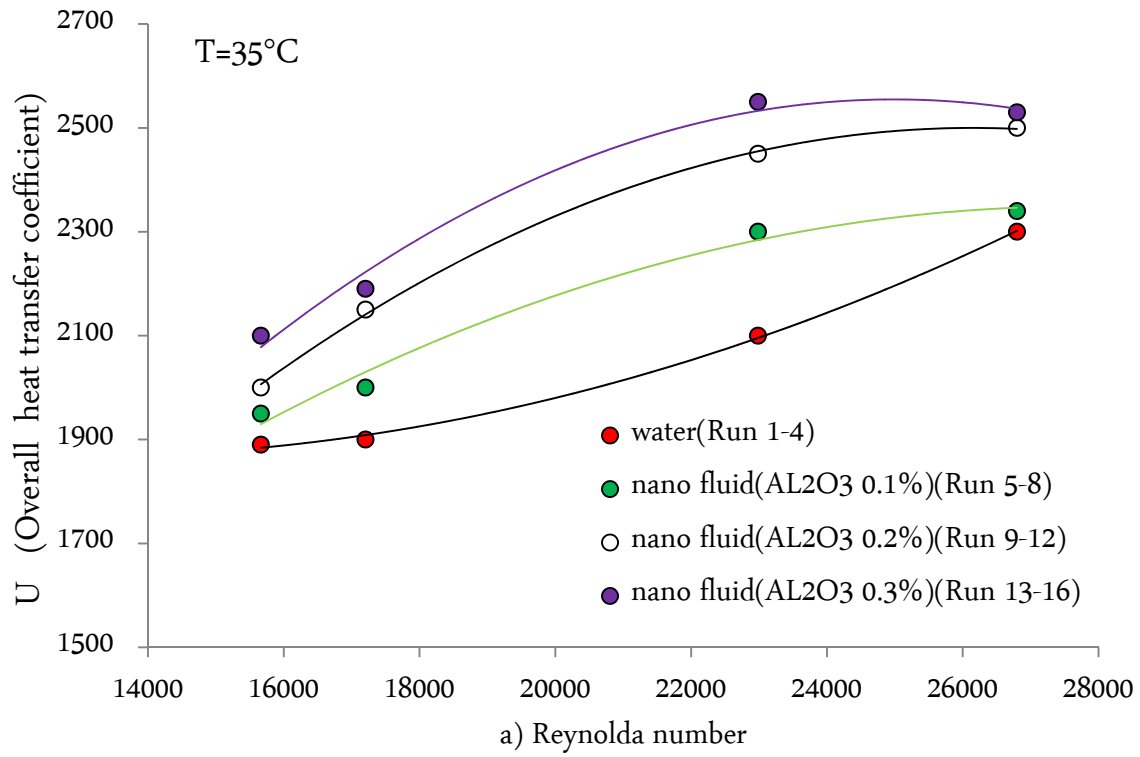

Fig.7. overall heat transfer coefficient versus Reynolds number changes at a) 35 and b) 40 °C

References

- [1] S. Choi, Developments and applications of non-Newtonian flows 452 (66) (1995) 99–105.
- [2] W. Dongsheng, D. Yulong, Experimental investigation into convective heat transfer of nanofluids at the entrance region under laminar flow conditions, *Int. J. Heat and Mass Transfer* 47(2004) 5181-5188.
- [3] X.W.Wang , X.F. Xu, S.U.S. Choi, Thermal conductivity of nanoparticle-fluid mixture, *J. Thermophys. Heat Transfer* 13(1999)474-480.
- [4] S.Lee, S.U.S Choi, Measuring thermal conductivity of fluids containing oxide nano particles, *J. Heat Transfer* 121(1999) 280-289.
- [5] P.Keblinski, S.R. Philpot, Mechanisms of heat flow in suspensions of nano-sized particles nano (nano fluids), *Int. J. Heat Mass Transfer* 45 (2002) 855-863.
- [6] S. Lee, , S.U.S. Choi, Applications of metallic nanoparticle suspensions in advanced cooling systems, International Mechanical Engineering Congress and Exposition, Atlanta, USA. (1996).
- [7] Y.M.Xuan, Q. Li, Investigation on convective heat transfer and flow features of nanofluids, *ASME J. Heat Transfer* 125 (2003) 151-155.
- [8] Y. He, Y . Jin, H. Chen, Y. Ding, D. Cang, H. Lu, Heat transfer and flow behavior of aqueous suspensions of TiO₂ nanoparticles (nanofluids) flowing upward through a pipe *Int. J .Heat Mass Transfer* 50 (2007) 22-72.